

Chipmeet

FORMATION FLYING STANDARD OPERATING PROCEDURES (SOP) DHC1 CHIPMUNK

This SOP has been compiled especially for the Chipmeet and differs mainly from the RAF SOPs on the following points:

- No intentional flying in IMC is allowed.

QuickTime™ en een TIFF (LZW)
decompressor zijn vereist om
deze afbeelding te bekijken.

CHIPMEET FORMATION FLYING

STANDARD OPERATING PROCEDURES (SOP)

DHC1 CHIPMUNK

1. These SOP are to be used as guidance for all formation flying by DHC1 Chipmunk aircraft during the Chipmeet.

BRIEFING

2. A briefing is to be given before every formation flight. All participants and instructors are to attend. The following points are to be covered where relevant:
 - a. Nomination of leaders and deputy leaders, and the positions of all aircraft in the formation.
 - b. The formation's *CALLSIGN*.
 - c. Weather at base, diversions and operating areas.
 - d. Notams.
 - e. R/T procedures.
 - f. Starting procedures.
 - g. Taxying and engine testing procedures.
 - h. Pre take-off checks.
 - i. Take-off procedure.
 - j. Climb procedure.
 - k. Sortie profile:
 1. Type of formations and spacing.
 2. Manoeuvres to be flown.
 3. Formation changes.
 4. Planned leader changes.
 5. Routine checks.
 6. Limitations to be observed.
 - l. Hand signals.
 - m. Lost contact procedures.
 - n. Recovery procedures and planned fuel calls.
 - o. Emergency procedures:
 1. Aborting take-off.
 2. Aircraft unserviceabilities on the ground and in the air.
 3. HEFOM code.
 4. Lost leader in VMC and IMC.

The following paragraphs expand on these points.

R/T PROCEDURES

3. The R/T briefing should include the following points:
 - a. Frequencies to be used and their sequence.
 - b. Collector frequency.
 - c. Action to be taken in the event of loss of R/T contact.
4. Pilots are to make individual checks of stand-by radios, and then listen out on the designated frequency. All checks-ins are to be initiated by the leader in the format "*CALLSIGN, CHECK IN*". The second aircraft is to check-in, using the format "*CALLSIGN 2*", further aircraft are to reply with their number only.
5. Formating pilots should squawk stand-by.
6. If R/T contact is not re-established after a frequency change, proceed as follows:
 - a. Listen out on the previous frequency for up to 30 seconds.
 - b. If contact is not re-established on the previous frequency, change to the briefed collector frequency. The leader may signal the change to the briefed collector frequency by raising the appropriate amount of fingers.
7. Orders on R/T are to be in the form of a 4-section transmission, e.g.: "*CALLSIGN, MANUAL 1, MANUAL 1, GO*".
8. Calls given for information may be given in a simplified form, e.g.: "*CALLSIGN, TURNING LEFT*".
9. The leader is to use the callsign "*CALLSIGN ONE*".

START UP

10. Ground crew are to be briefed on the position of each aircraft in the formation and the order of taxiing. The start up as briefed may be initiated by R/T, by hand signal, or at a pre-briefed time. Pilots experiencing unserviceabilities should inform the leader.

TAXYING

11. Aircraft are to be taxied slowly on the centreline with a minimum spacing of 50 metres between aircraft.

ENGINE TESTING and PRE TAKE-OFF CHECKS

12. Engine testing and pre take-off checks are to be completed at the holding point. Wingmen should close up but should take care to avoid the prop wash from the aircraft ahead. The leader should position on the downwind side of

the taxiway to assist wingmen to remain clear. The leader will signal the initiation of checks with a vertical rotating finger. A thumbs up should be passed from tail to leader to inform the leader that all aircraft are ready for take-off.

TAKE-OFF

13. Stream Take-Off.

- a. Aircraft are to line up in vic or echelon into any crosswind, using the standard formation references.
- b. When the wingmen are in position, they are to increase to 1500 RPM on the brakes and should indicate they are ready by a thumbs up. The leader signals rolling either by R/T, or by hand signal (Hand chopping action towards windscreen 3 times. Rolling on nod of the head). Power is increased to max power. Wingmen should roll at the briefed interval. The minimum stream interval is 5 seconds.
- c. All aircraft are to use full power for take-off. When safely airborne with the after take-off checks complete, the leader should reduce power to 1900 RPM and climb at 70 kts to 500 ft above airfield elevation before turning either level or climbing, to allow wingmen to catch up.
- d. The last aircraft should call “*CALLSIGN, AIRBORNE*” when safely airborne.
- e. In calm or very light wind conditions, a high-low-high profile should be flown to avoid wake turbulence. (Alternative procedure for busy airfields see Appendix 2, page 17)

14. Formation Take-Off.

- a. The maximum crosswind component for a formation take-off is 10 kts for a vic, 15 kts for a pair. Flaps 15° for grass runways and flapless for hard runways.
- b. Aircraft should line up in vic, or echelon into any crosswind if taking off as a pair plus a singleton, in the standard formation position. For a 2-ship formation carrying out a pairs take-off, the leader should line up in the centre of his half of the runway.
- c. When the wingmen are in position, they are to increase to 1500 RPM on the brakes and should indicate they are ready by a thumbs up. The leader signals rolling either by R/T, or by hand signal (Hand chopping action towards windscreen 3 times. Rolling on nod of the Head). Power is slowly increased to 2000 RPM. Take-off at 55 kts, climb at 70 kts.
- d. Wingmen are to maintain the normal lateral spacing throughout the take-off.
- e. If taking-off as a pair plus a singleton, the singleton (No.3) should roll at an interval of not less than 10 seconds, using max power.
- f. The last aircraft gives a call when airborne.
- g. Once safely airborne, the leader should adjust power to 1900 RPM. Speed 70 kts.

CLIMB

15. **Standard Climb.** The standard formation climb is at 70 kts, with the leader adjusting power to maintain 1900 RPM. The climb should be made in VMC.

FORMATION POSITIONS

16. Formation positions are shown in Appendices 4 to 6. When changing from vic to echelon left before breaking into a right hand circuit, aircraft will be in the order 1, 3, 2 and not 1, 2, 3.
17. Standard cruise setting: 1900 RPM.
18. Terminology for lateral positions is to be LEFT and RIGHT.
19. The references to be used for station keeping are:
 - a. **Vic or Echelon.**
 1. Longitudinally: wing tip opposite tailpane.
 2. Vertical: same height, i.e. upper and lower surfaces of the leader's wing visible.
 3. Lateral: full span between the wing tips, i.e. when the navigation light and spinner are in line when at the same time you are able to look along the elevator hinge line.
 - b. **Line Astern.**
 1. Vertical: just low enough to avoid slip stream.
 2. Longitudinal: one length between your nose and the tail of the aircraft ahead.
 3. Lateral: directly astern of the aircraft ahead with your wings parallel to those of the aircraft ahead.

CHANGING FORMATION

20. Formation changes are to be initiated by the leader, and acknowledged by all aircraft required to move. Formation changes are made by wingmen moving behind and below the leader. All movements are to be square, and the standard lateral or longitudinal separation is to be maintained at all times. A change of formation to reverse vic is only to be performed through line astern, or when rejoining close formation after a tailchase. The detailed procedures for changing formation are as follows:
 - a. **From Vic to Line Astern.**
 1. No.3 drops back and down and calls "*CALLSIGN 3, CLEAR*". He maintains a minimum of 1 length nose/tail separation on No.2.
 2. No.2 initially maintains position until No.3 is clear. Once No.3 calls "*CALLSIGN 3, CLEAR*", No.2 moves back and down to stabilise 1 length aft of the leader, and then moves across into position.
 3. No.3 moves in when he sees No.2 stabilised in position, and is to call "*CALLSIGN 3, IN*" when stabilised in position.

- b. **From Line Astern to Vic.**
 - 1. No.3 moves back 1 aircraft length and left, stabilises position and calls "*CALLSIGN 3, CLEAR*".
 - 2. No.2 maintains position until he hears No.3 call "*CALLSIGN X CLEAR*". He then moves right, up and forward into position.
 - 3. No.3 moves up and forward when he sees No.2 moving up and forward.
- c. **From Line Astern to Reverse Vic.**
 - 1. No.3 moves back one aircraft length and right, when stabilised in position, he calls "*CALLSIGN 3, CLEAR*".
 - 2. No.2 maintains position until he hears No.3 call "*CALLSIGN 3, CLEAR*". He then moves left, up and forward into position.
 - 3. No.3 moves up and forward when he sees No.2 moving up and forward.
 - 4. After the change, the leader is to call the formation to renumber.
- d. **From Vic to Echelon.**
 - 1. Only the moving wingman acknowledges. He then moves back and down to stabilise position with one length nose/tail separation on the other wingman.
 - 2. He then moves across, passing behind and below the formation, and stabilised position, before moving up and into position to join on the outside of the formation. He must never attempt to join between the leader and the other aircraft.
 - 3. When changing from vic to echelon left, the formation will be in the sequence 1, 3, 2.
- e. **Formations are not to form echelon from line astern.**

FORMATION LEADING

- 21. The leader is responsible for the safety of the formation. He must therefore pay close attention to lookout, navigation, weather and fuel, in addition to making decisions in the event of emergencies.
- 22. In the early stages of dual formation instruction turns are to be limited to 30 degrees of bank. Later the angle of bank may be progressively increased and climbing and descending introduced, building up to wing-overs. All entries to turns are to be made slowly to allow wing men to change power and maintain position. All changes of attitude are to be made smoothly and the leader must remember that his flexibility of manoeuvre is limited by the experience of the students. The power settings used must allow tolerance for the pilots in formation. Manoeuvres should avoid unnecessary exposure to sun glare.
- 23. Changes of lead are made on the orders of the formation leader and are normally to be made from echelon right, with the lead passing to the No.2. On change over, the leader is to pass the formation's position to the new leader in the following format, e.g.: "*CALLSIGN, POSITION X MILES ORIENTATION OF LOCATION, CALLSIGN 2 YOU HAVE THE LEAD*" No.2 is to acknowledge, and the change of lead occurs on acknowledgement. The ex-leader is to move clear of the formation, rejoin as briefed and squawk

stand-by. The new leader is to squawk mode C, renumber the formation and check the fuel states of the formation members.

ROUTINE CHECKS

24. Standard altimeter settings are to be used throughout. Pilots are responsible for completing regular cockpit checks. During initial sorties, aircraft are to move out to at least 2 spans spacing before carrying out cockpit checks. Once proficient, pilots may remain in close formation for checks. Fuel states are to be given in relation to the briefed Bingo figure. The first member of the formation to reach the briefed Bingo or Chicken figure is to inform the leader. On hearing one of these calls, other pilots should check their fuel, but should only report their fuel state if it is lower.
25. The meaning of the fuel calls are:
 - a. **Bingo 1.** Normally briefed as an information fuel check made early in the sortie to ensure that all aircraft are using fuel at the normal rate.
 - b. **Bingo 2.** Can be an extra fuel consumption check, or an action fuel state at which the leader wishes to commence a particular phase of the sortie as briefed. It is not always necessary to have 2 Bingo calls.
 - c. **Chicken.** Chicken is the minimum fuel to commence recovery in order to land with the minimum fuel required.

SIGNALS

26. Initially R/T may be used as required to pass instructions to the formation for manoeuvring and changes of aircraft configuration. In the early stages of formation training, R/T may be used freely to call turns etc, but should be dispensed with progressively, and replaced by hand signals if necessary. The formation hand signals to be used are contained in Appendix 1 to this SOP.

BREAKING and REJOINING THE FORMATION

27. **Break and Rejoin in Straight Flight.** Wingmen should obtain permission from the leader before practising break and rejoin. Only one aircraft at a time may break and rejoin. Procedure is as follows:
 - a. Acknowledge with “*CALLSIGN X OUT*”, initiate a climbing break away from the leader, using full power, at 45 degrees of bank, for 3 seconds .
 - b. After 3 seconds, reverse back onto the leader's heading, calling “*CALLSIGN X, VISUAL*” once the leader is sighted.
 - c. The leader gives instructions to the breaking aircraft to rejoin the formation. The leader may give the formation's altitude, heading and speed to help inexperienced pilots.
 - d. Rejoining aircraft should then enter a gentle diving turn towards the leader, reversing the turn to position offset by two spans and slightly low to their own side of the leader's 6 o'clock. Adjusting power as required to maintain 10 to 15 kts overtake.

- e. The initial approach must be made on a flight path parallel to and below the leader. Excess closing speed may be reduced by converting speed to height, but some vertical separation must be maintained until stabilised. Power should be used to stabilise position 2 spans out, slightly low on the tiedown on a line 2/3 down the cowling diagonal reference line, before closing slowly along the diagonal into position.
28. **Break and Rejoin in Turning Flight.** The turning rejoin may be practised from echelon, or used at other times (e.g. to join-up after a tailchase) as appropriate. To set up a practice turning rejoin, the leader should call "*CALLSIGN*, 3 SECOND BREAK, FOLLOW ME, FOLLOW ME, GO" or waves Goodbye. The leader should then break away using 45 degrees of bank through 90 to 120 degrees, and then reduce to 15 degrees of bank. Wingmen should follow at 3 second intervals and call: "*CALLSIGN X*, VISUAL". After the leader calls: "*CALLSIGN X*, REJOIN *ECHELON LEFT/RIGHT OR VIC*". Rejoin using the following technique:
- a. Wingmen should dive towards the centre of the leader's turn to position on the diagonal through the trailing edge of the leader's tail and outside wingtip, below the leader. Power should be adjusted to maintain a 5 to 10 kts overtake.
 - b. Approaching the leader, wingmen should descend to deep echelon - to allow a view of the underside of the lead aircraft.
 - c. If joining on the outside echelon, reduce bank to pass below and behind the leader, and stabilise position in a wide outside echelon. This is known as the waiting position.
 - d. If joining on the inside echelon, power is used to stabilise position 2 spans out below the leader's plane. This is known as the waiting position.
 - e. Once stabilised in the waiting position, join-up as for a join in straight flight.
 - f. If 2 or more aircraft are rejoining, the rearmost aircraft must keep the remainder of the formation in sight at all times, and is to maintain a minimum of 100 metres separation behind the aircraft joining ahead, until instructed to join by the leader. The leader is only to give the next aircraft instructions to join once he is satisfied that the first joining aircraft has achieved the stabilised waiting position.
 - g. If the first joining aircraft is joining on the outside echelon, once it has cross the leader's 6 o'clock, it must not, under any circumstances, re-cross to the inside of the turn.

TAILCHASE

29. Tailchasing is defined as a "follow-the-leader" exercise. At no time is a tailchase to be allowed to develop into a "dog fight", where the aim is to lose a following aircraft or to get on it's tail. The leader is to nominate a base height which none of the formation is to descend below, this height may be briefed on the ground or in the air, dependant on the prevailing weather conditions. Members of the formation are not to allow their spacing to reduce to such an extent that the safety of any aircraft in the formation is prejudiced. The maximum number of aircraft for tailchasing is 3.

30. The following limits are to be applied to tailchasing:
 - a. The leader is to ensure that the formation maintains VMC at all times.
 - b. The leader is to increase the recommended entry speeds for manoeuvres by 10 to 15 kts and he is not fly at an IAS or loading which would result in a following pilot's either losing control or exceeding aircraft limitations.
 - c. Minimum height as briefed.
 - d. Minimum vertical clearance from cloud as briefed.
 - e. Minimum spacing is 50 metres.
 - f. Leader is to pre brief min/max G-loads to be used in the tailchase.

31. The tailchase should normally be started from echelon right. The leader is to warn the formation by R/T in sufficient time for each pilot to complete the relevant aerobatic checks by calling: "*CALLSIGN, PREPARE FOR TAILCHASE*". A thumbs up should be passed from tail to leader to inform the leader that all aircraft are ready. The leader is to begin the tailchase by calling: "*CALLSIGN, MINIMUM ALTITUDE XXXX FT, TAILCHASE, FOLLOW ME, GO*". He is then to turn sharply away from the formation, through at least 90 degrees, with 2100 RPM set. Wingmen follow at 2-second intervals aiming for a spacing of 50 to 100 metres.

32. If a tailchasing aircraft is coming within 50 metres of the preceding aircraft, or is likely to come forward of the 4 or 8 o'clock arc relative to that aircraft, the pilot is to call "*CALLSIGN X, OUT*" and may add for example "*BREAKING RIGHT/LEFT*" as applicable. If No.2 breaks away, No.3 must follow him. Additionally pilots experiencing difficulty in regaining their position are also to call "*CALLSIGN X, OUT*". In either case the leader is to decrease the complexity of his manoeuvres and if necessary direct the rejoin. The tailchase may be continued when the aircraft, which broke out, indicates that he is in a suitable position to do so by calling "*CALLSIGN X, IN*".

33. In a tailchase it is the following pilot's responsibility to avoid the aircraft ahead and he must therefore maintain visual contact with the preceding aircraft at all times. If visual contact with the preceding aircraft is lost the pilot is to call "*CALLSIGN X, OUT, LOST VISUAL*". Following which, the leader is to level off, calling his flight level, and the aircraft which broke out is to establish at least 500 ft separation without flying through the leader's level. Subsequent aircraft are to maintain contact with the aircraft ahead. The leader is to pass the instructions to the aircraft which broke out to affect a join-up. When he regains visual with the leader, the aircraft which broke out should call "*CALLSIGN X, VISUAL*" and the tailchase may be continued when the joining aircraft indicates that he is in a suitable position to do so by calling "*CALLSIGN X, IN*".

34. A pilot faced with an aircraft emergency necessitating the termination of the tailchase is to call "*CALLSIGN, STOP, STOP, STOP*". The leader will then call the formation into an appropriate formation position.

35. Any member of the formation may terminate the tailchase by calling "*CALLSIGN*, KNOCK IT OFF, KNOCK IT OFF". When the tailchase is over, the leader is to call the formation into the appropriate formation position.
36. Before re-forming close formation, the leader is to call for a fuel check and indicate heading to be set on the DI. Formations are not to re-form in line astern.

RECOVERY

37. Prior to recovery, the leader should obtain the recovery airfield details and pass them to the formation. Pilots are to carry out the appropriate checks and set QNH before descent.
38. The leader should use a minimum power setting of 1500 RPM in the descent.

RUN IN

39. The leader should give the formation a straight run of at least 1.5 nm and, once lined up on the deadside, is to order the formation to the appropriate echelon. The minimum height for breaking is 500 ft agl.

BREAK and LANDING

40. At the appropriate position the leader is to call "*CALLSIGN*, BREAKING" and initiate a positive level break by rolling on 45 degrees of bank, applying full power and turning through 90 degrees. Power should be adjusted to maintain 90 kts and the aircraft flown to the normal circuit distance from the runway before turning into the downwind leg. The minimum time interval between breaking aircraft is 2 seconds.
41. When the leader breaks, the No.2 is to assume responsibility for the lookout of the formation, and maintain contact with the leader, while flying straight ahead for the briefed interval. The No.3 is to follow in turn using the same technique as No.2. The leader is to call downwind for the formation, but final calls are to be made individually. Wingmen should avoid flying below the flight path of the aircraft ahead to avoid wake turbulence. To this end, the leader should fly a slightly flatter than normal approach, the No.2 a normal approach, and the No.3 a slightly steeper approach. The minimum spacing on landing is to be 300 metres. All aircraft should land on the centreline, and move to the exit side of the runway when down to a fast taxi speed. Heavy braking should be avoided. The last aircraft is to call "*CALLSIGN*, RUNWAY VACATED" for the formation.

42. Formation leaders should emphasise the following points:
 - a. The necessity to go around immediately if a pilot experiences wake turbulence or has any doubt that his spacing on final approach or landing is less than the briefed minimum.
 - b. The importance of achieving the correct threshold speed, and the method and need to go around from a poorly judged approach.

VISUAL CIRCUITS

43. The circuit should be joined using standard joining procedures with the downwind leg being flown slightly wider than normal. Individual landing checks are to be made, but can be called by the leader, on finals. Full flap should be selected on finals. The leader should bear in mind the effect of bank on the airspeed of, and power required by the wingmen.

FORMATION LANDINGS

44. The following limitations apply to formation landing:
 - a. The maximum crosswind component is 15 kts for a pair, 10 kts for a vic. The pairs approach should be flown echelon into the crosswind.
 - b. Formation roller landings are prohibited.
45. The following techniques and procedures are to be used for a pairs landing:
 - a. The leader is to use half flaps and the wingmen are to use full flaps. The leader should fly a slightly flatter than normal approach, aiming to land slightly further up the runway than normal. The leader should call “*CALLSIGN, CUT*” after crossing the threshold when it is safe for the wingman to do so. He is to delay his own cut by 2 seconds.
 - b. The leader should land in the centre of his own half of the runway. After landing he should delay his braking to allow wingmen to space out behind him. Heavy braking should be avoided.
 - c. The No.2 should land in the centre of his own half of the runway. Once lined up on the final approach on a visual circuit, the No.2 should adjust position to line up in the centre of his half of the runway, by easing out along the diagonal reference line. Vertical position should be the same height as the leader. This appears slightly higher than the normal position and is achieved by putting the leader's head on the horizon. The landing is flown individually. Thus, the No.2 should not wait for the leader's cut call, but should treat it is a reminder to close the throttle if he has not already done so.
 - d. When down to a fast taxi speed, the No.2 should call the leader with clearance to cross to the exit side of the runway if appropriate by calling “*CALLSIGN 2 TAXI SPEED*”. The No.2 should call “*CALLSIGN, RUNWAY VACATED*” for the formation when appropriate.
46. If landing as a vic, procedures are similar to those for a pair, except that the leader should land on the centreline. Wingmen should maintain their standard lateral separation. To achieve this on a 150 ft wide runway they must land

close to their side, about 2/3 across. Wingmen should drop back very slightly on final approach to achieve nose/tail separation. If either No.2 or No.3 have a problem with braking, they are to call “*CALLSIGN, MOVE LEFT/RIGHT*” to direct the leader to the opposite side of the runway, out of the way.

4 SHIP FORMATIONS

47. The following 4 ship formations, illustrated in Appendix 6, may normally be flown:
- Box. The No.4 position is slightly further aft and down from a normal line astern position. He should be directly behind the leader, positioned such that he has the correct echelon references on No.2 and No.3.
 - Line Astern.
 - Finger Four.
 - Swan.
 - Echelon.
48. **4 Ship Take-Off.**

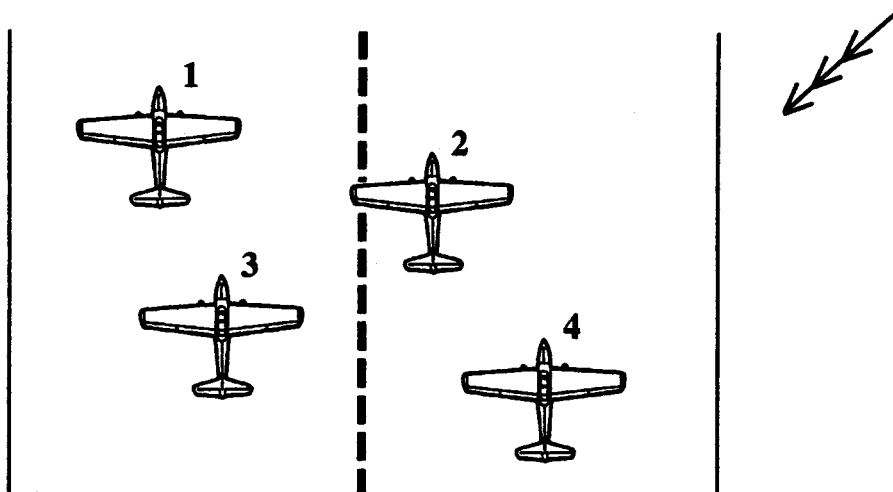

For a 4 ship formation, take-off is normally to be as 2 pairs at a minimum interval of 10 seconds. Alternatively, take-off may be as a vic and a singleton. The runway spacing between the vic and the singleton on line-up is to be 50 meters and the minimum interval is to be 10 seconds.

If the wind is outside pairs limits (10 kts) an individual stream take-off should be used with a minimum interval of 5 seconds. Aircraft should be lined up on the runway in 2 echelons into wind. No.2 should have the wheel nearest the leader on the runway centre line.

NOTE: If taking-off with the crosswind from the left, the line up should be a mirror image of that shown above, i.e., Nos.1 and 3 remain element leaders with Nos.2 and 4 lining up in the echelon left position on their element lead.

After take-off, the element leaders should individually call their wingmen into the required echelon before the formation joins up.

1. **Join-up.** The join-up is to be made to box or finger 4 formation as briefed. Nos.3 and 4 may be briefed to join the formation either individually or as a pair.
 2. **Climb.** Formations are not to penetrate cloud.
49. **Formation Changes.** All formation changes, except from finger 4 to echelon on the same side and swan to line Astern are to be made through box as follows:
- a. **Box to Finger 4.** No.4 moves back, across, up and forward into the echelon on the appropriate side.
 - b. **Finger 4 to Box.** No.4 moves back, down, across and up into the box position.
 - b. **Finger 4 to Echelon.** The No.2 (for echelon left) or the No.3 (for echelon right) moves back and down until he can see the other 3 aircraft and then moves across and up into position on the outside of the echelon.
NOTE: Because of the lack of manoeuvrability of the formation in this position it should normally only be used on recovery for the run in and break.
 - d. **Box to Echelon.**
 1. No.4 moves back and across into echelon on the appropriate side and calls "*CALLSIGN 4, IN*".
 2. When the No.2 (echelon left) or No.3 (echelon right) hears No.4 is in, he moves back and down until he can see all 3 aircraft, and then moves across into position on the outside of the echelon.
NOTE: 4 ships in echelon left will be in the sequence 1, 3, 4, 2.
4 ships in echelon right will be in the sequence 1, 2, 4, 3.
 - e. **Echelon to Box.**
 1. The pilot on the outside of the echelon moves back, down, across and up into position on the opposite side, and calls "*CALLSIGN X, IN*" when in position.
 2. On hearing the "in" call, the No.4 moves back and down until he can see all 3 aircraft and moves across into the box position.
 - f. **Box to Line Astern.**
 1. No.2 and No.3 move back and down and call clear.
 2. No.4 moves forward into position.
 3. No.2 moves across, up and forward into position.
 3. No.3 remains clear until No.2 is in position, then moves across, up and forward into position and calls in.
NOTE: 4 ships in line astern will be in the sequence 1, 4, 2, 3.
 - g. **Line Astern to Box.**
 1. No.3 moves back, down and across and calls clear.
 2. No.2 moves back, down and across and calls clear.
 3. No.4 eases back to the correct astern position.
 4. No.2 and No.3 move forward and up into position.
 - h. **Box to Swan.**
 1. No.2 and No.3 move out, down and back with No.2 taking his timing from No.3.
 2. When No.2 and No.3 are clear and moving back, No.4 moves forward to the line astern position on No.1.

3. No.2 and No.3 then adopt the standard formation position relative to No.4.

j. **Swan to Box.**

1. No.4 moves down and back into his box position. No.2 and No.3 maintain position on No.4 until he is settled.
2. No.2 and No.3 then move out, down, forward and up into position on No.1.

k. **From Swan to Line Astern.**

1. No.3 drops back and down and calls clear.
2. No.2 initially maintains position, when No.3 is clear, he then moves back, down and across into position.
3. No.3 moves in when he sees No.2 stabilised in position and is to call "CALLSIGN 3, IN" when stabilised in position.
4. No.4 smoothly adjusts his line astern position as briefed.

l. **From Line Astern to Swan.**

1. No.3 moves back and across and calls clear.
2. When No.3 is clear, No.2 moves across, up and forward.
3. No.3 moves up and forward into position when he sees No.2 moving in.
4. No.4 smoothly adjusts his line astern position as briefed.

50. **Tailchasing.** 4 ship tailchases are prohibited.

51. **Recovering and Normal Break.** 4 ship formations may be recovered for a run in and break from echelon, or as a vic and a singleton, or as 2 pairs with No.1 leading No.2, and No.3 leading No.4. In the last 2 cases the formation is to split on a briefed signal from the leader and the minimum landing distance between a vic and a singleton or between 2 pairs is to be 1000 meters. Formation changes in 4-ship operations which result in non-sequential numbering, e.g. echelon port, should be carefully briefed to avoid misunderstanding in the air.

OPPOSITION BREAK

52. An opposition break may be flown from box provided that it has been specifically briefed, the circuit is clear and the crosswind is less than 10 kts. The procedure to be used is as follows:

- a. The leader is to call the break:
"CALLSIGN, BREAK, BREAK, GO ... 2 second pause ... BREAK, BREAK, GO".
- b. On the first "GO", No.2 and No.3 break right and left respectively.
- c. On the second "GO", No.1 and No.4 break left and right respectively.
- d. The leader calls downwind for the formation:
"CALLSIGN, 4 AIRCRAFT LEFT AND RIGHT DOWNWIND TO LAND".
- e. No.2 turns finals first, No.3 turns finals when No.2 is halfway round the turn. No.4 turns finals when No.3 is halfway round the turn, and No.1 turns finals as No.4 is halfway round the turn. Individual aircraft call finals in the sequence 2, 3, 4, 1.

- f. Pilots should maintain the minimum spacing on landing as laid down in para 41.

EMERGENCIES

53. Aborted Take-Off.

- a. **Formation Take-Off.** If a wingman needs to abort take-off, the other aircraft in the formation should continue, except when the abort is caused by an obstruction on the runway, or when speed is very low. If the leader aborts, the entire formation should also abort. A wingman aborting should action the abort and then call “*CALLSIGN X, ABORTING*”. If it becomes necessary for the whole formation to abort take-off, and if time and circumstances permit, the leader should call “*CALLSIGN, ABORT, ABORT*”, before he takes abort action.
- b. **Stream Take-Off.** If an aircraft aborts a stream take-off, he should call “*CALLSIGN X, ABORTING*”. All aircraft behind him should also abort. The aircraft aborting should maintain its line down the runway.

- 54. **In Flight.** A pilot with an emergency in flight is to inform the leader aircraft by R/T and carry out individual corrective action. The leader is to assist the aircraft in distress, as necessary, or appoint another aircraft captained by a qualified pilot to do so.

55. Radio Failure.

- a. **Wingmen.** A wingman should indicate a radio failure by moving out and forward into the line abreast position and attract the leader's attention by rocking his wings. The unserviceability is to be indicated by using the appropriate hand signals. The leader will then lead the unserviceable aircraft back to base using the pre-briefed recovery procedure.
- b. **Leader.** The leader should indicate a radio failure by gently rocking his wings. If the formation is in line astern or during a tailchase, this is also the signal to change to vic. The leader will use visual signals to indicate the extent of his unserviceability. He will then point to the deputy leader and then hold up one finger to indicate No.1, to indicate that he is handing over the lead. The new leader should then lead the unserviceable aircraft back to base, using the pre-briefed recovery procedure.
- c. **HEFOM Code.** In the event of an aircraft with total radio failure experiencing a further emergency, the following procedure is to be used:
 - 1. Move forward and rock his wings to attract the leader's or deputy leader's attention.
 - 2. He should then raise a clenched fist to the top of the canopy to indicate his intention to use the HEFOM code. The leader or deputy should acknowledge this signal by repeating it back.

3. The pilot should then indicate the unserviceability by holding up the required number of fingers to denote the nature of the emergency as follows:

HYDRAULICS	1 Finger.
ELECTRICS	2 Fingers.
FUEL	3 Fingers.
OIL	4 Fingers.
MOTOR	5 Fingers.

The leader or deputy should acknowledge by repeating the signal.

56. Loss of Leader in IMC. The leader is to use a maximum of 30 degrees of bank in IMC. A wingman losing sight of the leader in IMC is to transfer immediately to instruments, and break away as follows:
 - a. **In Straight Flight.**
 1. Turn 20 degrees away from the leader, using 20 degrees of bank, and maintain the heading for 20 seconds.
 2. If climbing: continue. If descending: level off.
 3. Inform the leader.
 4. After 20 seconds, resume the leader's original heading and proceed as instructed.
 - b. **Outside Wingman in a Turn.**
 1. Roll wings level for a minimum of 20 seconds.
 2. If climbing: continue. If descending: level off.
 3. Inform the leader, stating heading.
 4. Proceed as instructed.
 - c. **Inside Wingman in a Turn.**
 1. Increase bank to 45 degrees and regain level flight.
 2. Inform the leader, stating heading passing.
 4. The leader will roll out of his turn immediately and pass instructions.

Leaders are to pass instructions to wingmen losing contact to ensure they maintain safe separation initially, and are then to order either a join-up or an individual recovery as appropriate. Both leader and wingmen should be mindful of safety altitude.

57. **Loss of Leader in VMC.** If a wingman loses sight of his leader in VMC, he should proceed as follows:
 - a. Inform the leader immediately “*CALLSIGN X, LOST VISUAL*” and call his height.
 - b. Enter a turn. The leader will maintain vertical separation, enter a turn and affect a join-up using GPS, VOR, DME or a visual fix.

Appendix 1

FORMATION HAND SIGNALS

Start Up (not normally used)	Vertical finger rotating
Engine Wind Up (other times)	Vertical finger rotating
Ready for Taxi / Take-Off roll	Thumbs up to the leader
Starting Take-Off Roll	Chop hand 3 times, start rolling on nod head
Increase/Decrease Power	Fist forward / fist backward
Turning (if required)	Hand vertical, palm towards direction of turn, 3 times, roll on third
Straight Ahead	Hand chopping action to windscreen 3 times, roll out on third
Climb/Descent	Single finger, point up / down
Level Off	Hand Palm flat, move side to side
Fuel Check	Leader: drinking action Wingmen: thumbs up/down
Change Echelon	Leader points to aircraft to move and to new position
Radio Transmitter Failure	Point mike, thumbs down
Radio Receiver Failure	Point ear, thumbs down
Line Astern	Fist on back of head
Reform Original Formation (after L/A or Tailchase)	Wing rock
Change Leader	Point at new leader, raise one finger
On the Break	Leader waves Goodbye
Flap Down	Hand flap action, 3 times, nod head
Cut Engine	Vertical finger rotating, cut throat

Appendix 2

13b. Alternative Procedure for Stream Take-Off.

NOTE: To be used at busy airfields.

- a. After the thumbs up signal from the wingmen up to the leader indicating that everybody is ready for departure, The leader is rolling into position for the take-off, uncaging his DG and immediately commences his take-off
- b. Wingmen do the same commencing the take-off roll at the briefed interval.
- c. All aircraft using max power until safely airborne and after take-off checks completed. Leader is reducing power to 1900 RPM climbing out with 70 kts to allow the wingmen to catch up.
- d. The last aircraft should call "*CALLSIGN X, AIRBORNE*".
- e. In calm or light wind conditions a high-low-high profile should be used to avoid wake turbulence.

Appendix 3

RADIO CALLS SUMMARY

Identification of the formation is done by a *CALLSIGN*, e.g. "RED FORMATION", "BLUE FORMATION", ...

The leader is identified as: "*CALLSIGN ONE*".

Check-in:

- No.1: "*CALLSIGN*, CHECK-IN "
- No.2: "*CALLSIGN TWO*"
- No.3: "THREE "
- No.4: "FOUR"

Change of Radio Frequency:

- No.1: "*CALLSIGN*, MANUAL TWO, MANUAL TWO, GO"

Airborne:

Last aircraft when airborne calls: "*CALLSIGN*, AIRBORNE"

Break and Rejoin:

- No.1 "*CALLSIGN X*, BREAK (AND REJOIN E *L/R or VIC*)"
- No X "*CALLSIGN X*"
- ...
- No X "*CALLSIGN X*, VISUAL"
- No.1 "*CALLSIGN X*, REJOIN (E *L/R or VIC*)"
- No.X "REJOIN (E *L/R or VIC*), *CALLSIGN X*"
- ...
- No X "*CALLSIGN X* "

Change of leader (from echelon right):

- No.1 "*CALLSIGN* POSITION *Y* MILES *ORIENTATION* OF *LOCATION*, *CALLSIGN 2* ON MY BREAK YOU TAKE THE LEAD"
- No.2 "*CALLSIGN TWO*"
- No.1 Breaks
- No.2 (new lead) "*CALLSIGN*, RENUMBER"
- No.2 (old No.3) "*CALLSIGN TWO*"
- No.3 (old No.1) "THREE"

Formation Change:

From Vic to Line astern (3-ship)

- No.1 "*CALLSIGN*, LINE ASTERN, LINE ASTERN, GO"
- No.2 "*CALLSIGN TWO*"
- No.3 "THREE"
- ...
- No.3 "THREE CLEAR"
- ... when in position:
- No.3 "THREE IN"

Appendix 3 (continued)

RADIO CALLS SUMMARY

Checks:

No.1 “*CALLSIGN, AEROBATIC/DOWNWIND/LANDING CHECKS*”

Tailchase:

No.1 “*CALLSIGN, PREPARE FOR TAILCHASE*”

No.1 “*CALLSIGN, MINIMUM ALTITUDE XXXX FT, TAILCHASE, FOLLOW ME, FOLLOW ME, GO*”

...

No.X Aircraft unable to maintain position or endangering the formation is breaking away and calls “*CALLSIGN X, OUT*” (eventually followed by “*BREAKING LEFT/RIGHT*”).

When safely clear of the formation and visual he calls: “*CALLSIGN X, VISUAL*”

...

No.X Aircraft who wants to terminate the tailchase calls: “*CALLSIGN, KNOCK IT OFF, KNOCK IT OFF*”

...

No.X Aircraft in an emergency calls: “*CALLSIGN, STOP, STOP, STOP*”

...

No.1 If the leader wants to terminate the tailchase he calls: “*CALLSIGN, KNOCK IT OFF, KNOCK IT OFF*” and calls the formation to an R/V point. Or the leader calls for a direct rejoin in echelon (L/R) of Vic (L/R)

Break and Landing:

No.1 At the pre-briefed point: “*CALLSIGN, BREAKING*”

No.X Last chipmunk to clear the runway calls: “*CALLSIGN, RUNWAY VACATED*”

Emergencies:

If the lead aircraft has to abort the take-off he calls:

No.1 “*CALLSIGN, ABORT, ABORT*”

If one of the other participants has to abort the take-off, he calls:

No.X “*CALLSIGN X, ABORTING*”

All aircraft in front of "X" continuing the take-off, the other aircraft are to abort the take-off run immediately using brakes and rudder to avoid the affected aircraft and the other participants.

Loss of lead IMC / VMC:

No.X “*CALLSIGN X, LOST VISUAL, MAINTAINING XXXX FT, HEADING XXX*”

No.1 Guides “X” to a visual or calls him for a rejoin over a reference point.

Appendix 4

2 SHIP FORMATIONS

Echelon Right (E/R)

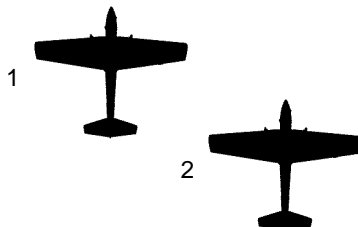

Echelon Left (E/L)

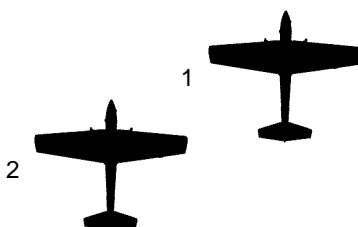

Line Astern (L/A)

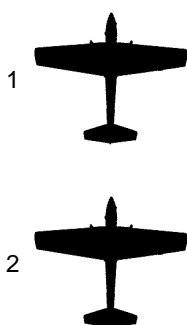

Line Abreast (L/Abr)



Appendix 5

3 SHIP FORMATIONS

Vic (VIC)

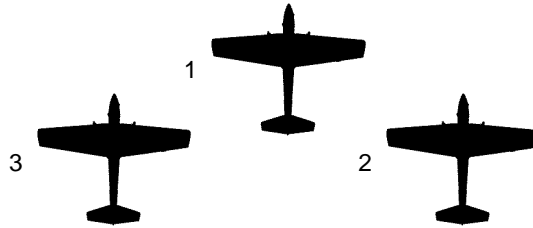

Echelon Right (E/R)

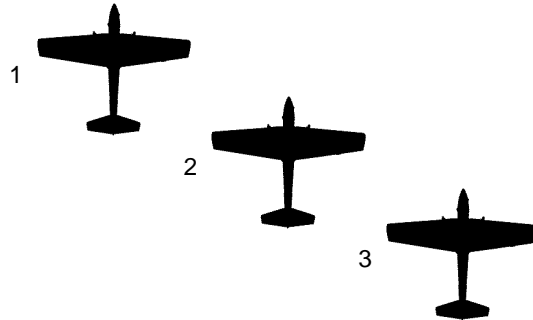

Echelon Left (E/L)

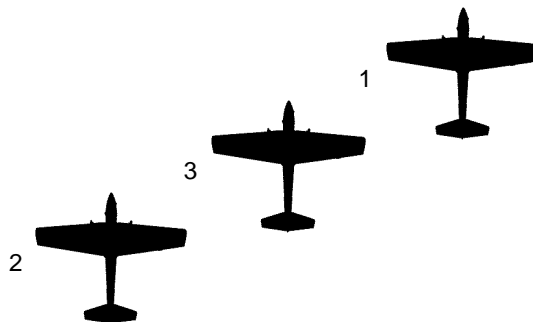

Appendix 5 (continued)

3 SHIP FORMATIONS

Line Astern (L/A) from VIC

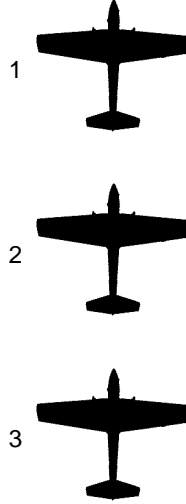

Appendix 6

4 SHIP FORMATIONS

Box (BOX)

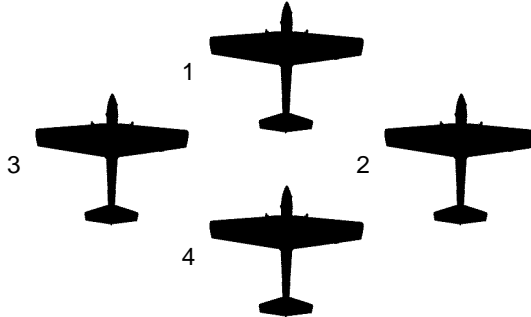

Echelon Right (E/R)

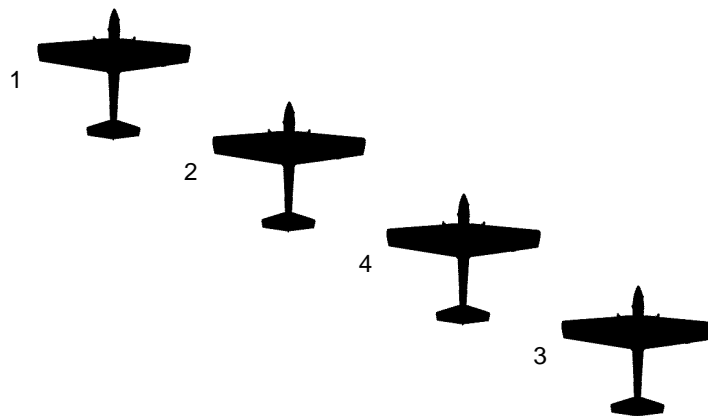

Echelon Left (E/L)

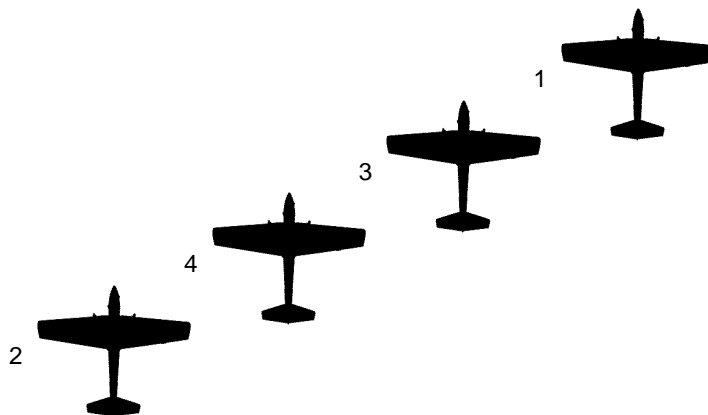

Appendix 6 (continued)

4 SHIP FORMATIONS

Finger Four Right (FF/R)

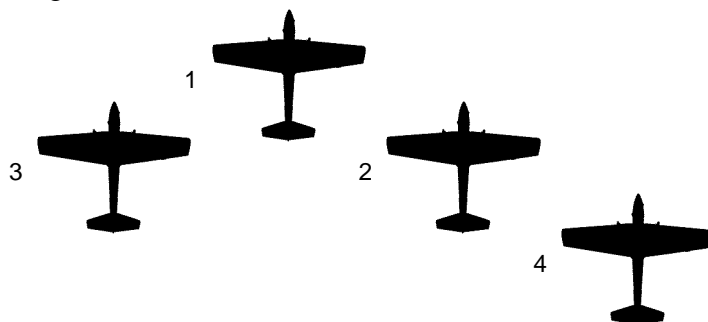

Finger Four Left (FF/L)

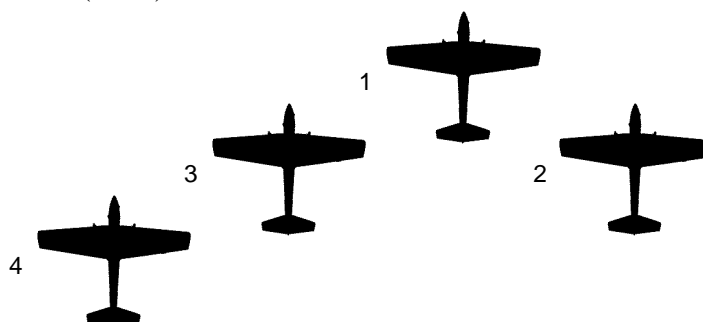

Appendix 6 (continued)

4 SHIP FORMATIONS (continued)

Line Astern (L/A)

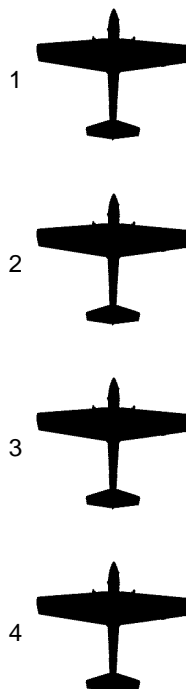

Swan (SW) from BOX

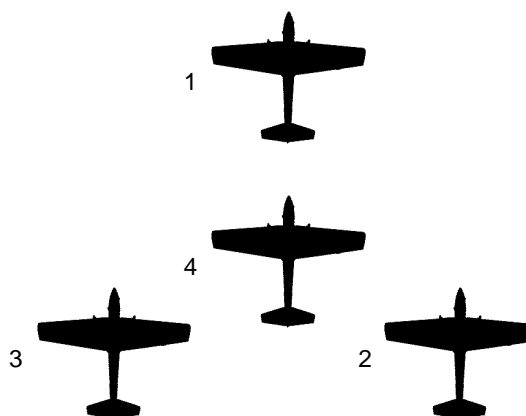

Appendix 7

FORMATION FLIGHT LOG

Formation flight log cards will be available in abundance at the Chipmeet, so each participant may use a new card for each sortie. This will enable each participant to keep a good record of the work accomplished and progress made.

Time Check		Callsign		
Walk	M1	M5	Block	
CXIN HT/CLD	M2	M6	B1	
TO	M3	M7	B2	
Slot/EET	M4	M8	Chick	
SUTTO	Route/diversion		WX	
W/V				
Join Up			BadWX plan	
RV	Crash			
NOTAM	Recovery		EMERGENCY	
Hazard/Obst.			Abort T/O	
			A/C U/S	
			RT	
Airex			EFOM	
			PEFOM	
			HEFOM	
			lost lead VMC	
NR.	CREW	A/C	COLOR	Sect.
1				
2				
3				
4				